

The Mobile Environment Monitoring System with a Web Interface

Nataliia Furmanova, Galina Shilo, Anton Kalynychenko, Pavlo Kostianoi

Department "Information technology of electronic devices", Zaporizhzhia National Technical University, UKRAINE, 69063, Zaporizhzhia, Zhukovskogo str., 64, shilo.gn@gmail.com, nfurmanova@gmail.com

Abstract: In the scientific work the mobile system has been developed that will allow to remotely control the level of atmospheric air pollution. The statistic data of air pollution are shown at the developed web site. These statistics is allowed to forecast the air pollution at the district

Keywords: air pollution, environment monitoring, ecological device, software complex, mobile system.

I. INTRODUCTION

Environmental monitoring is complex observations of the environment, including components of the natural environment, natural ecological systems, processes in them, phenomena, assessment and changes forecast of the environment.

The development of monitoring as a complex method of the gathering information about the observed object and its activity analysis allows to talk about the formation of an information monitoring technology that combines diagnostics (assessment of the current), genesis (assessment of the past), and the forecast (assessment of the future) of the state of the studied objects [1].

This article proposes the development of a software and hardware complex that will allow remote control over the level of air pollution. This complex can be used by installing remote monitoring modules at multiple points to control emissions produced by industry and cars and quickly provide control environmental conditions for a rapid response structures of civil defense and labor protection in enterprises and government agencies.

II. FORMULATION OF THE PROBLEM

Issues of environmental monitoring are relevant today. This is evidenced by a large number of scientific papers on this topic. Thus, in [2, 3] environmental monitoring is considered as a part of Smart Cities and the importance of control with air content in urban cities is emphasized.

Different mathematical models are used for solving the task of modeling air pollution. In [4] forecast methods of the ecological situation on the basis of a hidden Markov model are specified. Using the interval difference operators for analysis of air pollution from vehicular traffic is proposed in [5]. Wireless sensor networks using Wi-Fi are proposed in [6], but this decision has some constraints, so we are proposed using SIM modem.

III. THE MAIN FEATURES

Following steps realize the processing of information in the developed monitoring system:

- measurement of gases in the air;
- processing information by microcontroller;
- recording results on the server;
- presenting results on the site;
- view the given information by end-users.

Existing air pollution monitoring devices do not have the ability to transmit data for their analysis remotely.

Based on the considered analogs, we have put forward and implemented the following requirements:

A. Modularity

To be able to use complex on different objects, cities, countries-complex must have universal measurements. This flexibility has been achieved by using a series of sensors MQ, which allow you to measure a huge range of gases without changing the polling algorithm.

B. Measurement ranges

It can be achieved the following ranges of measurements of different gases with a combination of different sensors:

- LPG and propane: 200ppm-5000ppm
- Butane: 300ppm-5000ppm
- Methane: 5000ppm-20000ppm
- H₂: 100ppm-10000ppm
- Alcohol: 100ppm-2000ppm
- CH₄ and natural gas: 200-10000ppm
- LNG and iso-butane: 200-1000ppm
- Carbon-monoxide: 20ppm-2000ppm
- Ozone: 10-1000ppm
- Ammonia, Benze, Hydrogen: 10ppm-10000ppm
- H₂S: 1ppm-200ppm
- Ammonia: 5ppm-500ppm
- Toluene, Acetone, Ethanol: 5ppm-500ppm

C. Data gathering

The complex provides remote collection of information from a variety of monitoring modules located at a great distance from each other. The collection is carried out by transferring information from each module to the server using the SIM800L GSM modem. This solution has some advantages in comparison with the using of Wi-Fi. Firstly, mobile communication covers significantly larger territories. Secondly, in the absence of communication device will write data in the memory and send them later.

D. Presentation of information

The ability to display information in the form of interactive graphs using any device with Internet access is implemented, as well as daily, weekly, monthly sampling data with information about exceedances.

TABLE 1. MQ SERIES

Model	Target Gas
MQ-2	General combustible gas
MQ-3B	Alcohol
MQ-4	Natural gas, Methane
MQ-5B	LPG, Natural gas, Coal gas
MQ-6	LPG, Propane
MQ-7B	Carbon Monoxide (CO)
MQ-8	Hydrogen
MQ-9B	CO and Combustible gas
MQ131	Ozone O ₃
MQ135	Air Quality Control (NH ₃ , Benzene, Alcohol, smoke)
MQ136	Sulfureted Hydrogen (H ₂ S)
MQ137	Ammonia (NH ₃)
MQ138	VOC (Mellow, Benzene, Aldehyde, Ketone, Ester)

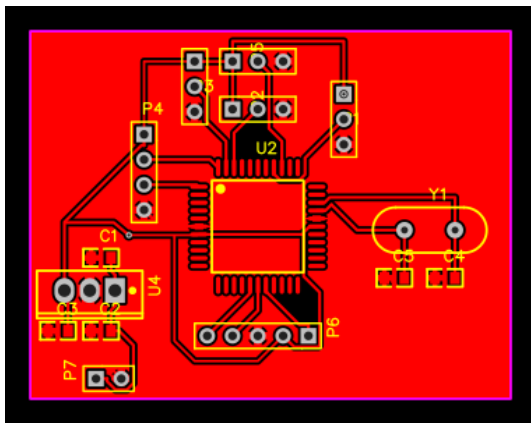

Fig. 3. Photorealistic image of the PCB.

The appearance of the printed circuit board is shown at the Fig. 4.

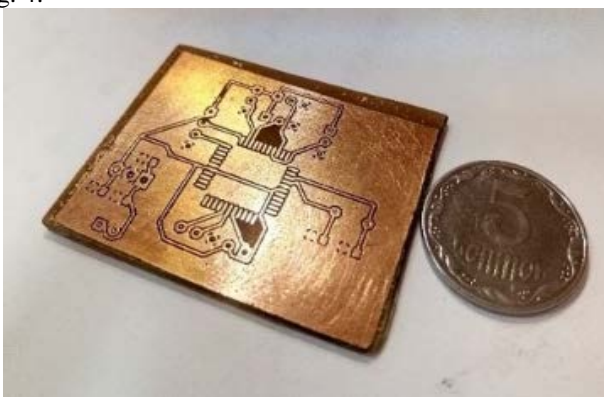

Fig.4. The appearance of the produced PCB.

F. The housing of device

For the developed PCB of the device, we designed a rectangular shaped housing made of plastic. Since the model

is developed as a prototype, to test the housing and the device as a whole, housing parts were manufactured by 3D printing using a 3D printer for FDM technology. PLA (polylactide) based on environmental materials was chosen as the material. Diameter of the used plastic fibers is 1.75 mm, which is due to the features of the printer structure. A three-dimensional model was created in the SolidWorks system (Fig. 5).

The housing consists of four parts: the base, partitions with sensor mount and a lid. The overall dimensions of the assembled housing are 70x70x40 mm. After testing it is possible to produce a series of pressure casting housings, that will reduce the cost of the housing unit as a whole in mass production.

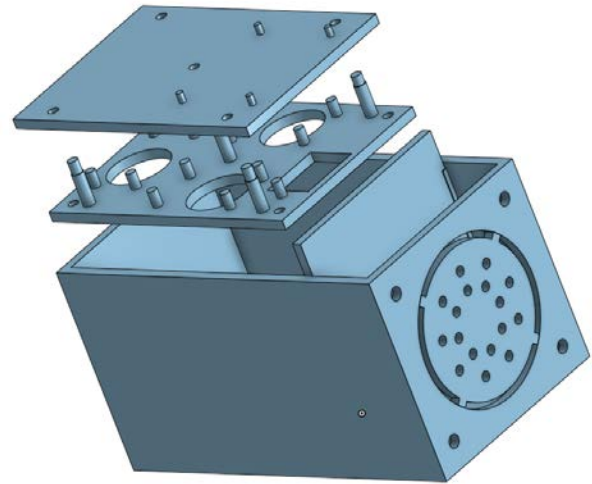

Fig. 5. The housing model without a lid.

IV. SOFTWARE

A. The software part of a module

When the module is turned on, the microcontroller calibrates the MQ-X gas sensors, and then it initializes the connection to the GSM module. After that, the cyclic starts measure the level of air pollution, the information is gathered from the sensors and sent it to the server. The time between measurement and sending can be changed from 10 seconds to several days.

During the delay between the measurements, the controller switches to sleep mode, which reduces power consumption.

If the connection to the GSM module has not been established, the microcontroller will write the data into memory and retry the sending of data at the next cycle pass.

Sending data to the server occurs through the HTTP POST request. This allows to record the readings in the form of a JSON string and to process on the server side easy.

B. The Server

The work of the complex is to monitor a large area and collect information from a variety of modules. Therefore, it is necessary to store, process and submit a fairly large flow of information, so we chose the following software tools:

- 1) MySQL - Database management system, which is used to store information received from modules.
- 2) WEB server (in particular nginx HTTP server + php) - using REST requests, we can use it both to receive

information from the modules and display information to the end user.

C. Server Software

When the SIM800 modem installed in the module is accessed to the server, the script parses the incoming JSON string to an array of data from each sensor, as well as information about the module, and places these data to the database.

Information about the database tables used for the operation of the complex is given below (Table II, Table III).

TABLE 2. TABLE DEVICES

Column name	Information
Id	Record number (table key)
Address	The physical address of the installation
Name	The device name
Description	Device description / Notes

TABLE 3. TABLE READINGS – INFORMATION FROM SENSORS

Parameter	Meaning
Id	Record number (table key)
Dev_id	ID of device
Datetime	Time and date of data fixation
Temp	Temperature from DHT22 sensor
Humidity	Humidity DHT22 sensor
Module1	Sensor 1 readings
...	...
Module9	Sensor 1 readings

D. User Interface

When designing the complex, the ability to view information from any device in an easy and understandable way has provided. Therefore, for these purpose it was decided to create a web interface and present data in the form of interactive graphs. Experimental results are shown in [7].

The web application was written in javascript, which makes a selection for a given period of time and displays this data using the library chart.js.

V. CONCLUSION

In this paper, a system for environmental monitoring is proposed. A module has been developed that will allow to monitor the level of air pollution remotely.

The low cost of the developed module will make it possible to produce and install a large number of modules for environmental monitoring to cover extended areas.

The following tasks were solved. The automation system for determining the concentration of gases in the atmosphere by means of sensors was studied. An algorithm for the

functioning of the device is developed. A layout and trace of the printed circuit board were created; performance characteristics were calculated. The technology of production of parts and assemblies was chosen an experimental model was created. A system for storing, processing and reporting information on air pollution in a user-friendly form was developed.

Analysis of the collected information on the state of the environment, taking into account rose winds allows to determine the source of emissions of certain gases; to simulate environmental conditions and predict the movement of air currents in the event of emergencies.

Features of the developed ecological monitoring system:

- a wide range of air pollution coverage;
- the possibility of modification or individual assembly on request of the customer;
- small, in comparison with similar devices, cost;
- relatively simple process of production using typical technological processes;
- gathering information from a set of modules located at different points.

These properties allow using a proposed system for educational purposes. It was realized at the Zaporizhzhia National Technical University in form of laboratory stand. This stand was developed to study the basics of data analysis by students. The stand allows them to vary the components of the modules, test their operation in practice and improve its features using modern approaches for gathering and analysis of data.

REFERENCES

- [1] J. Awange, and J.B. Kyalo Kiema, *Environmental Geoinformatics: Monitoring and Management*, New York, Springer, 2013, 533 p.
- [2] H. Song, R. Srinivasan, T. Sookoor and S. Jeschke, *Smart Cities: Foundations, Principles, and Applications*, Wiley; Hoboken, NJ, USA: 2017.
- [3] M. Bacco; F. Delmastro; E. Ferro and A. Gotta "Environmental Monitoring for Smart Cities," *IEEE Sensors Journal*, Vol. 17, Issue: 23, 2017, pp. 7767 – 7774
- [4] Wei Sun, Hao Zhang, Ahmet Palazoglu et al., "Prediction of 24-hour-average PM2.5 concentrations using a hidden Markov model with different emission distributions in Northern California", *Science of the Total Environment*, pp. 93-103, 2013.
- [5] I. Voytyuk, N. Porplytsya, A. Pukas and T. Dyvak "Identification the interval difference operators based on artificial bee colony algorithm in task of modeling the air pollution from vehicular traffic," *14th International Conference The Experience of Designing and Application of CAD Systems in Microelectronics (CADSM)*, 2017, pp. 58-62.
- [6] M. Pavani, P.T. Rao, "Real time pollution monitoring using Wireless Sensor Networks", *2016 IEEE 7th Annual Information Technology Electronics and Mobile Communication Conference (IEMCON)*, pp. 1-6, 2016.
- [7] Statistics of air pollution monitoring: <http://ecomon.devus.tk>