

INVESTIGATION OF A TRANSFER BRANCH OF A FLEXIBLE SCREW CONVEYER

ДОСЛІДЖЕННЯ ПЕРЕВАНТАЖУВАЛЬНОГО ПАТРУБКА ГНУЧКОГО ГВИНТОВОГО КОНВЕЄРА

Prof. Ph.D. Eng Hevko R.B.¹⁾, Lect. Ph.D. Eng. Klendii M.B.²⁾, Ph.D. Eng. Klendii O.M.²⁾

¹⁾Ternopil National Economical University / Ukraine; ²⁾Separated Subdivision of National University of Life and Environmental Sciences of Ukraine Berezhanly Agrotechnical Institute / Ukraine

E-mail: alex_ks@mail.ru

Keywords: screw conveyer, transfer branch, screw, technological line

ABSTRACT

Having analysed the researches on the operating process of screw conveyers, a transfer branch with a central drive has been offered to be mounted between uploading and unloading pipe lines. This helps to increase the length of bulk load conveying and to decrease power load on helixes at the point of their attaching to drive shafts. Process flow sheets of possible ways of conveying bulk load in a transfer branch have been developed and its experimental sample has been made. Theoretical and experimental investigations of the process of conveying bulk load between operating devices in a transfer branch have been conducted.

РЕЗЮМЕ

На основі аналізу результатів досліджень процесів роботи гвинтових конвеєрів запропоновано між завантажувальною та вивантажувальною магістралями встановити перевантажувальний патрубок з центральним приводом. Це дозволяє збільшити довжину транспортування сипких матеріалів, а також знизити силові навантаження на спіралі в зоні їх кріплення до привідних валів. Розроблено технологічні схеми можливих варіантів переміщення сипкого матеріалу в перевантажувальному патрубку та виготовлено його експериментальний зразок. Проведено теоретичне дослідження процесу переведення сипкого матеріалу між робочими органами в перевантажувальному патрубку та проведено експериментальні дослідження.

INTRODUCTION

Transfer branches in flexible screw conveyers are widely used for uploading and unloading process operations. However, the existing designs of transfer branches do not meet exploitation requirements in full measure. Main disadvantages are the following: an increased energy consumption, which is connected with the need of lifting the material at the point of its transfer in order to provide a gravity flow from a loading pipe line to an unloading one; the increased damage of grain material and the complexity of branch designs, especially at their considerable overall size.

In the familiar designs of transfer branches (Boyko A.I. and Kulikiskiy V.L., 2011; Hevko R.B. and Klendiy O.M., 2013; Klendiy M.B., 2006; Klendiy M.B. and Hevko R.B., 2005; Klendiy M.B., 2007), in which the above mentioned problems are partially solved, the process of bulk load transfer becomes more complicated and under some operating conditions there is an increased possibility of congestion, which can cause a crash of a flexible screw conveyer.

MATERIAL AND METHOD

In order to improve the performance criteria of flexible screw conveyers, diagrams of the directions of bulk load transfer from a loading pipe line to an unloading one have been suggested, and the design of a transfer branch with a central drive and a safety device with unloading of screw operating devices in a horizontal plane has been designed (Hevko R.B. and Klendiy O.M., 2014; Hevko R.B. et al., 2014; Hevko R.B. et al., 2015; Hevko R.B. et al., 2012; Hevko R.B. et al., 2014). In order to choose the optimal design of a transfer branch of a screw conveyer, let us consider various directions of bulk load transfer by operating devices from an uploading pipe line to an unloading one (Klendiy M.B., 2006) (Fig.1).

In the first alternative, when using a leftward helical spiral with screw operating devices turning in the same counterclockwise direction (Fig.1, a), bulk load is transferred along the bottom horizontal surface of a transfer branch. When using a rightward helical spiral with screw operating devices turning in the same clockwise direction (Fig.1,b), bulk load is transferred along the upper horizontal surface of a transfer branch.

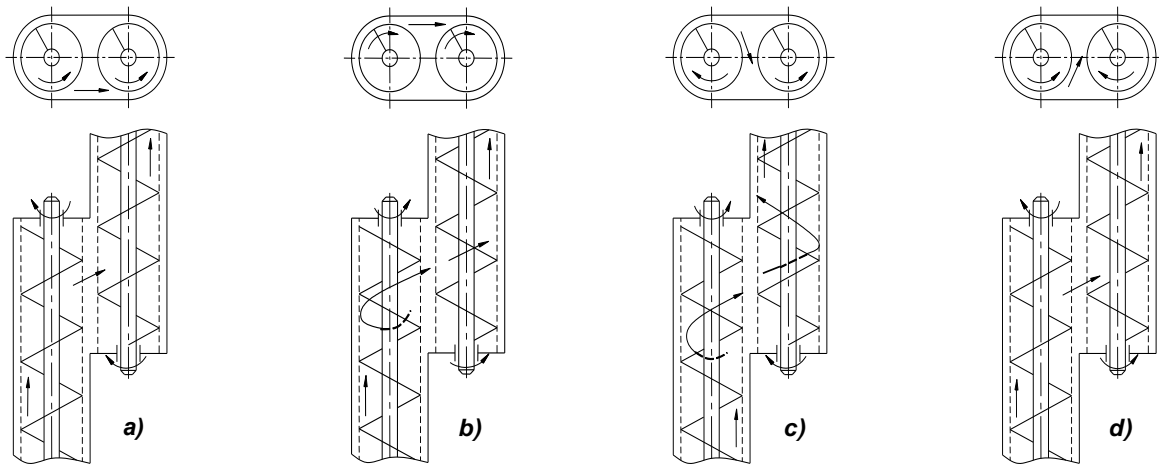

Fig.1 - Diagrams of the directions of bulk load transfer from an uploading pipe line to an unloading one

In the other alternative, bulk load transfer in a transfer branch can be provided by spirals turning in different directions for transferring from a loading pipe line to an unloading one at the point of transfer (Fig.1, c, d).

Design concept and overview of a transfer branch of a screw conveyor are represented in Fig.2.

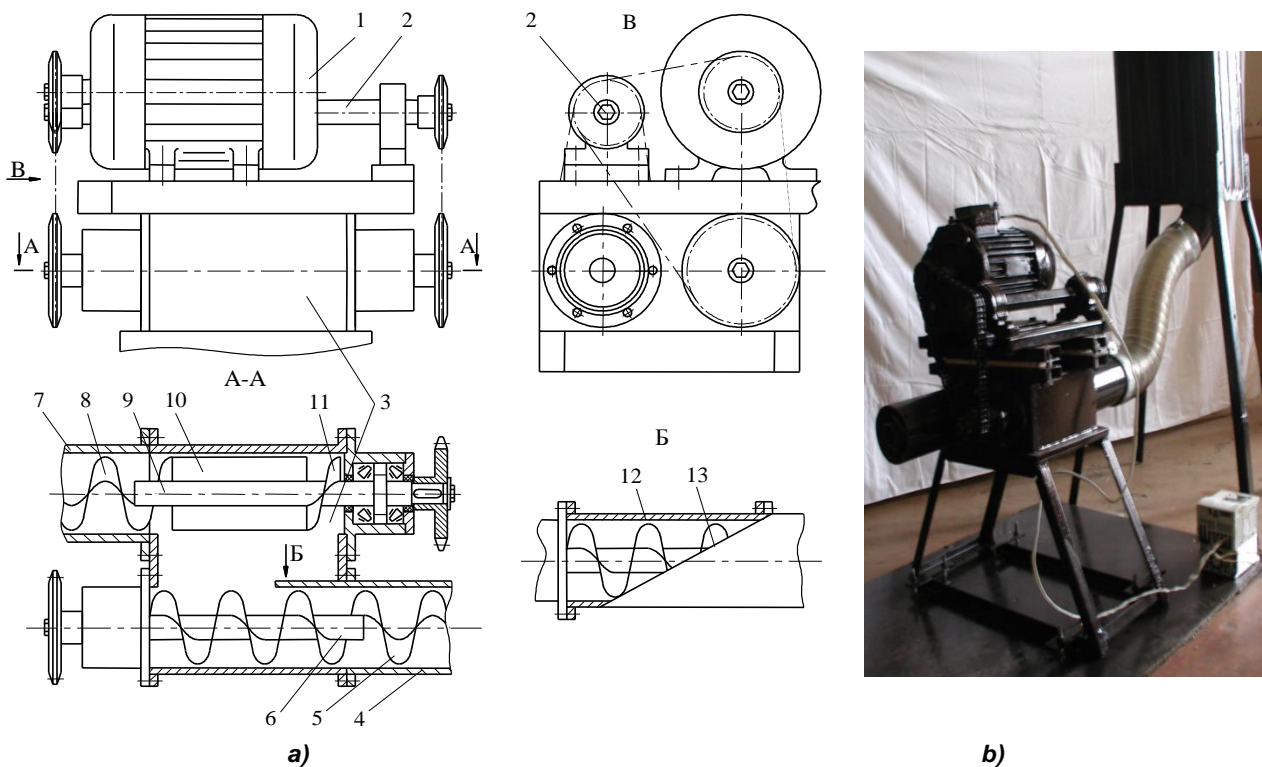

Fig.2 – Design concept (a) and overview (b) of a transfer branch of a flexible screw conveyor

It contains uploading and unloading pipe lines, which are made in the form of casings 7 and 4 and uploading 8 and unloading 5 operating screw helixes mounted in parallel, which are attached on driving shafts 9 and 6 respectively. A countershaft 2 is arranged in parallel with driving shafts fixed on a transfer branch 3; driving and counter shafts outside a transfer branch are joined in kinematics terms with an electric motor shaft 1 and placed in a horizontal plane. Radial plates 10 are attached on a shaft 9, and on the other side there is a sector of a screw helix 11, which coiling direction is the opposite of the one of an operating loading screw helix 8. An unloading screw helix 5 in a transfer branch is arranged in a conductor cylindrical tube 12, where there is a wedge-shaped cut out 13 made on the side of radial flat plates.

While in operation, kinematically joined driving shafts, a counter shaft and an electric motor shaft provide the rotation of operating screw helixes. While feeding bulk load, a helix 8 transfers it in a casing towards a transfer branch. Since driving shafts are arranged in a horizontal plane, material feeding on an unloading pipe line is carried out by radial flat plates. A sector of a screw helix 11 provides bringing of the whole bulk load mass together on radial flat plates in order to avoid congestion. Further, bulk load gets onto an unloading operating screw helix, which draws it into a wedge-shaped cut out in a tube 12 and moves it in a casing towards the unloading area. Availability of a wedge-shaped cut out provides gradual input of material into a cylindrical tube that changes into a casing 4, which facilitates the decrease in damaging bulk load.

Arrangement of shafts in a horizontal plane with the use of radial plates and a conductor cylindrical tube with a wedge-shaped cut out provides the transfer of bulk load from an uploading pipe line to an unloading one in a horizontal plane, which facilitates the increase in operational reliability of a conveyer at general decrease in energy consumption. In addition, torque, which acts upon every operating device, is reduced, which enables proportional increase of the length of transportation.

In order to investigate the conveying of material, a mathematical model of the process of bulk load transfer in a transfer branch has been developed as:

$$\omega_B = \frac{\omega T (T - \mu \pi D \operatorname{sgn} \omega)}{(\pi D)^2 + T^2}$$

$$T_B = T \left(1 - \frac{\omega}{\omega_B} \right) \tag{1}$$

$$v_0 = \frac{\omega T T_B}{2\pi (T - T_B)}$$

where ω_B - angular velocity of the rotation of the material transported; T - pitch of a screw; T_B - pitch of a helical line of load conveying; ω - angular velocity of screw rotation; μ - friction coefficient of the material conveying along the screw surface taking into consideration capillary phenomena; D - screw diameter; v_0 - axial velocity of load conveying.

In the system (1) it is customary, that the value for leftward screws is $\operatorname{sgn} \omega = -1$, and for rightward ones it is $\operatorname{sgn} \omega = 1$. The determined mathematical model is applicable for high-speed screws, which specific speed is $\frac{\omega^2 D}{2g} > 1$.

Suppose, the entry of a screw into a transfer branch is perpendicular to the axis of a screw and load throwing is carried out on the half of an open flight rightwards in case of axial feeding of an observer, as it is shown in Fig.3.

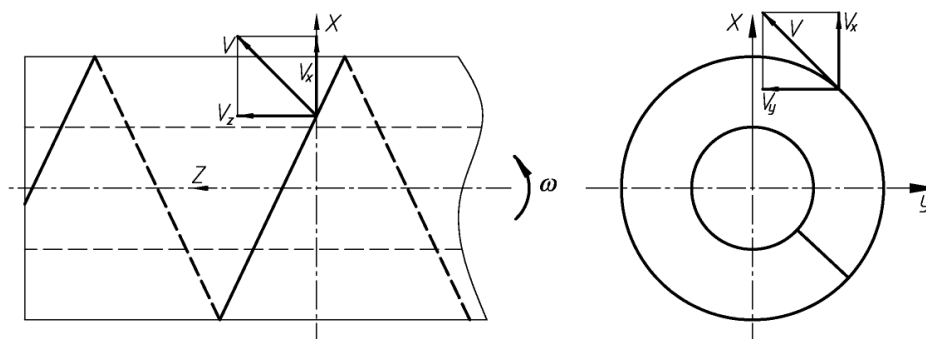

Fig.3 – Design diagram for determination of bulk load movement

In case of a rightward screw, which turns in counter clockwise direction, load throwing is done at a screw entry from below a screw; in case of a leftward screw load throwing is carried out from above.

For both of the cases mentioned, dependencies to determine the points of throwing and escaping velocity of load particles have been deduced:

In case of a rightward helical spiral:

$$\begin{aligned}
 X_B &= R \sin \omega t; \\
 Y_B &= R(1 - \cos \omega t); \\
 Z_B &= 0; \\
 v_x &= \omega_B R \cos \omega t; \\
 v_y &= \omega_B R \sin \omega t; \\
 v_z &= v_0;
 \end{aligned} \tag{2}$$

In case of leftward helical spiral (suppose $\omega > 0$, however, turning is in clockwise direction):

$$\begin{aligned}
 X_B &= R \sin \omega t; \\
 Y_B &= R(1 + \cos \omega t); \\
 Z_B &= 0; \\
 v_x &= \omega_B R \cos \omega t; \\
 v_y &= -\omega_B R \sin \omega t; \\
 v_z &= v_0,
 \end{aligned} \tag{3}$$

where X_B, Y_B, Z_B – coordinates of a point of separation of a particle from a screw; v_x, v_y, v_z - components of particle velocity along corresponding axis; $R = D/2$ - radius of a screw.

A particle moves under predetermined starting conditions until its interaction with the bottom surface of a screw for the time, which is determined under free fall under the influence of gravity acceleration:

$$t = \frac{\sqrt{v_y^2 + 2gY_B} + v_y}{g} \tag{4}$$

Coordinates of a particle fall point are calculated according to the following dependencies:

$$\begin{aligned}
 X_P &= X_B + v_x t \\
 Z_P &= Z_B + v_z t.
 \end{aligned} \tag{5}$$

RESULTS

Dependency of coordinates of a conveying load fall point on a change of various parameters of operating devices has been investigated with the help of a Delphi program with graphical presentation of results. The results of the analysis are represented in the form of graphical dependencies (Fig.4).

Having analysed graphical dependencies (Fig.4, a), it has been stated that particles of conveying material are thrown at a distance of 40–60 mm (parameter X_P), which provides their reaching a receiving (unloading) screw without causing congestion. Positive value of Z_P shows, that longitudinal direction of particle flow takes place in the direction of the conveying material; that is why, mutual axial displacement of feeding and receiving screws by the amount, which is approximate to that of a half pitch of a screw, is reasonable.

As a result of the investigation, it has been determined, that inside a transfer branch there should be about two flights of each screw in order to provide load transfer without causing congestion and damage.

In order to have reliable transfer of bulk load, which gets from a leftward screw to a receiving one, the latter should be made in such a way as to capture material inside an operating device of a bottom surface of a branch, that is to say, this screw needs to be rightward.

As a result of the analysis of graphical dependencies (Fig.4, b, c, d), it has been stated that for the improvement of transfer process a pitch of a screw and a friction coefficient of material are of importance. Minor dependence of the distance of throwing on the diameter of a screw can be explained by the fact, that for a stable pitch, an increase in the diameter results in an increase in the helix angle of a screw.

Having analysed graphical dependencies (Fig.4, a), it has been stated that particles of conveying material are thrown at a distance of 40–60 mm (parameter X_P), which provides their reaching a receiving (unloading) screw without causing congestion. Positive value of Z_P shows, that longitudinal direction of particle flow takes place in the direction of the conveying material; that is why, mutual axial displacement of feeding and receiving screws by the amount, which is approximate to that of a half pitch of a screw, is reasonable.

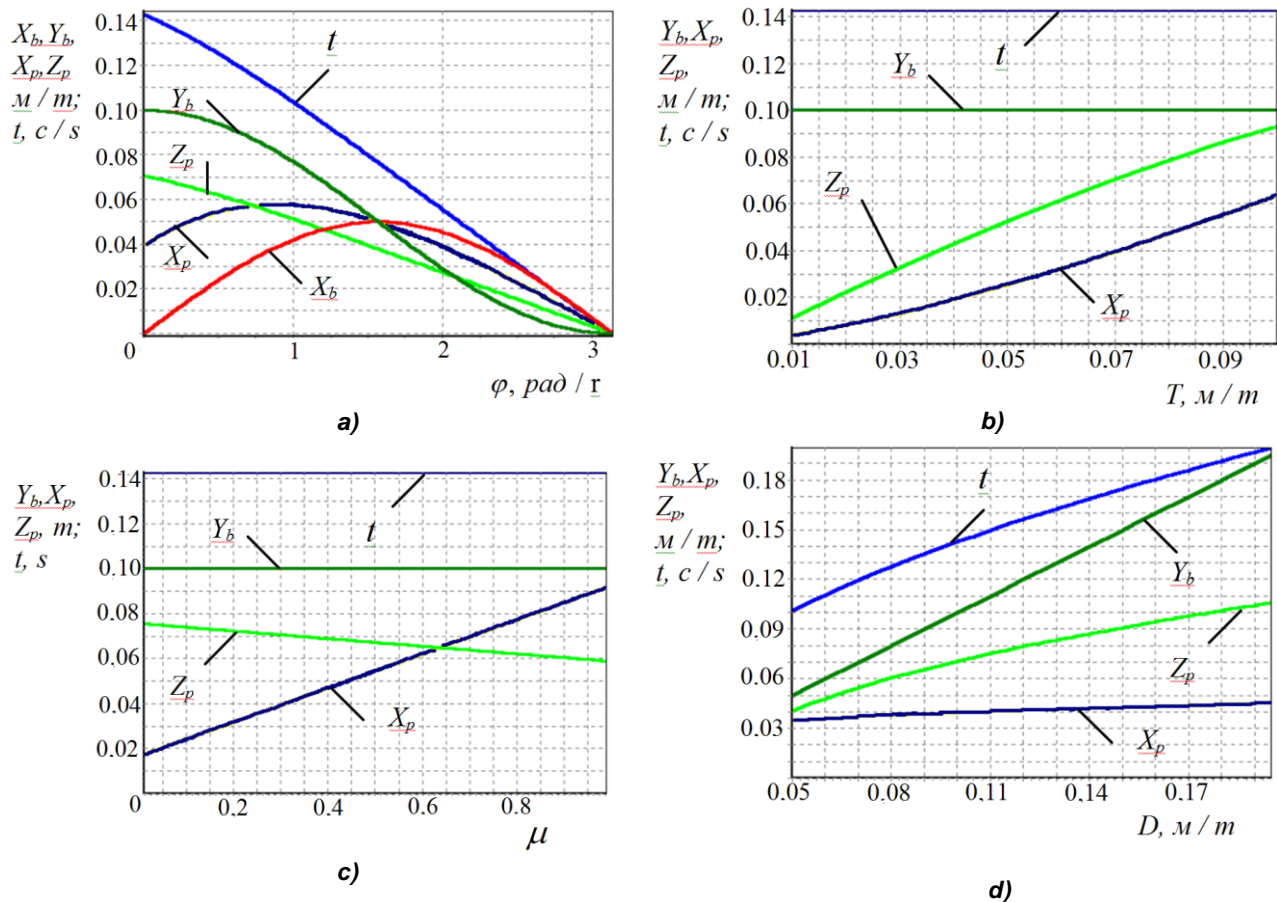

Fig.4 – Dependency of a point of separation of material from an operating surface and a point of its fall on the surface of a screw when being thrown by a leftward screw

a) on an angular velocity; b) on a pitch; c) on a friction coefficient; d) on a diameter

As a result of the investigation, it has been determined, that inside a transfer branch there should be about two flights of each screw in order to provide load transfer without causing congestion and damage.

In order to have reliable transfer of bulk load, which gets from a leftward screw to a receiving one, the latter should be made in such a way as to capture material inside an operating device of a bottom surface of a branch, that is to say, this screw needs to be rightward.

As a result of the analysis of graphical dependencies (Fig.4, b, c, d), it has been stated that for the improvement of transfer process a pitch of a screw and a friction coefficient of material are of importance. Minor dependence of the distance of throwing on the diameter of a screw can be explained by the fact, that for a stable pitch, an increase in the diameter results in an increase in the helix angle of a screw.

As a result of the experimental investigations conducted, it has been stated, that the productivity of a transfer branch Q increases proportionally to an increase in the frequency of the rotation of operating devices n and decreases with an increase of a slope angle of a screw body to the horizon. Over the range of n changing from 300 RPM to 800 RPM Q increases in 2-2.4 times, while as changes from 0° to 30° Q decreases in 45-55%.

As a result of a multiple-factor experiment, regression equation has been obtained; after its analysis it has been determined, that for the designed transfer branch, over the range of the parameter change of $96 < D < 98$ (mm); $300 < n < 700$ (RPM) and $0 < \alpha < 30$ (degrees) the dominant factor, which influences the degree of grain material damage is the value of clearance between the rotating surface of an operating device and a casing, next it is the frequency of its rotation and a slope angle of a transfer branch to the horizon.

CONCLUSIONS

Having reviewed patents and existing research works on the operation of transfer branches in screw conveyers, a new design of a transfer branch has been suggested, which enables to increase the length of material conveyance at generally lower energy consumption. Having analysed process flow sheets of the

possible options of bulk load conveying, a transfer branch has been developed and made.

Theoretical investigation of the process of bulk load transfer with the help of a screw operating device of a conveyer in a horizontal transfer branch has been carried out.

It has been stated that feed particles are thrown by a feeding screw at a distance of 40-60 mm in the axial direction, that is why, mutual axial displacement of feeding and receiving screws by the amount, which is a half pitch of a screw, is reasonable. From analysis of graphical dependencies it follows, that in the middle of a transfer branch there should be about two flights of each screw in order to provide material transfer without congestions and damage. In addition, it has been determined, that a pitch of a screw and a friction coefficient of material are of importance and a screw diameter counts little. That is why, it is reasonable to choose the diameter of a screw according to the productivity, and a pitch value as $T = (0.6-0.8) D$.

The results represented in the article may be used for engineering design of a transfer branch of a flexible screw conveyer.

REFERENCES

- [1] Boyko A.I., Kulikiskiy V.L., (2011), Investigation of contact grain interaction in gap “coil-jacket” of screw feeders grain cleaning machines (Дослідження контактної взаємодії зерна в зазорі “виток-кожук” шнекових живильників зерноочисних машин). *Scientific Bulletin of NUBiP-K.: Red species*. Department NUBiP 201, Vol.166, Engineering and Energy AIC, P.1, pp.267-274;
- [2] Hevko R.B., Klendiy O.M., (2014), The investigation of the process of a screw conveyer safety device actuation, *INMATEH - Agricultural Engineering Journal*, vol.42, no.1, pp.55-60, Bucharest/Romania;
- [3] Hevko R.B., Dzyura V.O., Romanovsky R.M., (2014), Mathematical model of the pneumatic-screw conveyor mechanism operation, *INMATEH-Agricultural Engineering Journal*, vol.44, no.3, pp.103-110, Bucharest/Romania;
- [4] Hevko R.B., Zalutskiy S.Z., Tkachenko I.G., Klendiy O.M., (2015), Development and investigation of reciprocating screw with flexible helical surface, *INMATEH - Agricultural Engineering Journal*, vol. 46, no.2, pp.133-138, Bucharest/Romania;
- [5] Hevko R.B., Vitrovyi A.O., Pik A.I., (2012), Advance in technology of flexible screw conveyers: monograph (*Підвищення технічного рівня гнучких гвинтових конвеєрів: монографія*), p.204, Aston, Ternopil;
- [6] Hevko R.B., Klendiy O.M., (2013), Methodology of investigation of a screw conveyer with a safety device (Методика проведення досліджень шнекового транспортера із запобіжним пристроєм), *Agricultural Machinery: Scientific works. (Сільськогосподарські машини: Збірник наукових статей)*, no.24, Edition of Lutsk NTU, pp.67–75, Lutsk;
- [7] Hevko R.B., Hlado U.B., Shynkaryk M.I., Klendiy O.M., (2014), Dynamic calculation of a safety device of a screw conveyer (Динамічний розрахунок запобіжного пристрою шнекового транспортера), *Bulletin of Engineering Academy of Ukraine (Вісник інженерної академії України)*, no.2, pp.163–168, Kyiv;
- [8] Klendiy M.B., (2006), Investigation of transfer process of bulk load by screw operating devices (Дослідження процесу перевантаження сипкого вантажу гвинтовими робочими органами), *Bulletin of Ternopil Ivan Puliui State Technical University (Вісник Тернопільського державного технічного університету імені Івана Пулюя)*, Vol.3, pp.92-100, Ternopil;
- [9] Klendiy M.B., Hevko R.B., (2005), Methodology of investigation of new types of transfer branches of screw conveyers (Методика досліджень нових типів перевантажувальних патрубків гвинтових конвеєрів), *Scientific Works of Vinnytsia State Agrarian University (Збірник наукових праць Вінницького державного аграрного університету)*, Vol.20, pp.190–195, Vinnytsia;
- [10] Klendiy M.B., (2007), Development and parameters validation of paddle conveyor-mixer design (Розробка конструкції та обґрунтування параметрів лопатевого транспортера-змішувача), *Scientific Bulletin of National Agricultural University*, Vol.92, P.2, pp.533-540.